

LOWER TREADMILL COMPONENTS  
SEE PAGES 2 THRU 6

DISPLAY / CONSOLE COMPONENTS  
SEE PAGE 7

TARGAS AND HANDRAILS  
SEE PAGE 8

C934	P/N 45788-102	REV: K
DRAWN BY: GRANADOSIN	DATE: 05.07.04	SHEET 1 OF 8

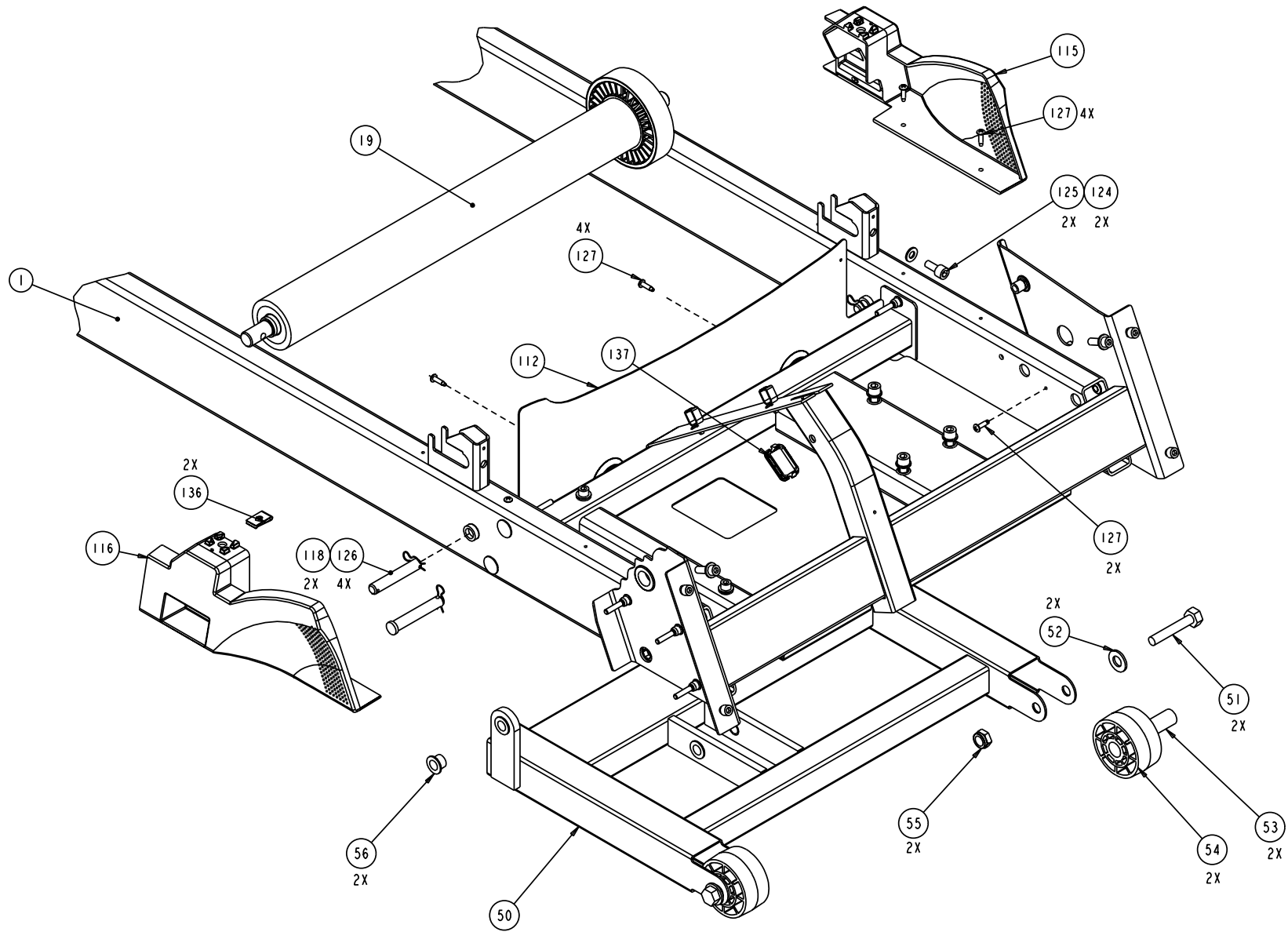

C934	P/N 45788-102	REV: K
DRAWN BY: GRANADOSIN	DATE: 05.07.04	SHEET 2 OF 8

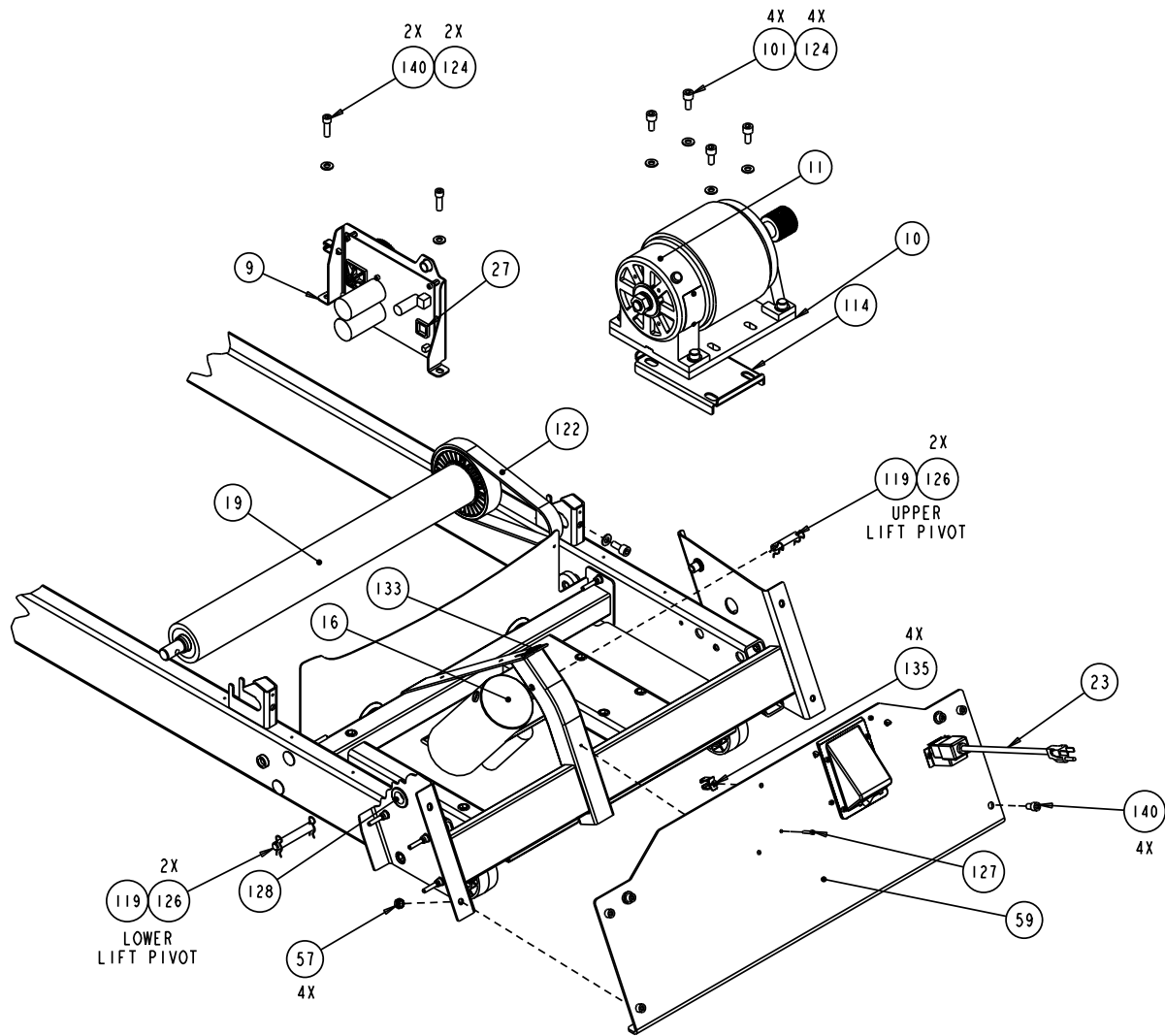

C934	P/N 45788-102	REV: K
DRAWN BY: GRANADOSIN	DATE: 05.07.04	SHEET 3 OF 8

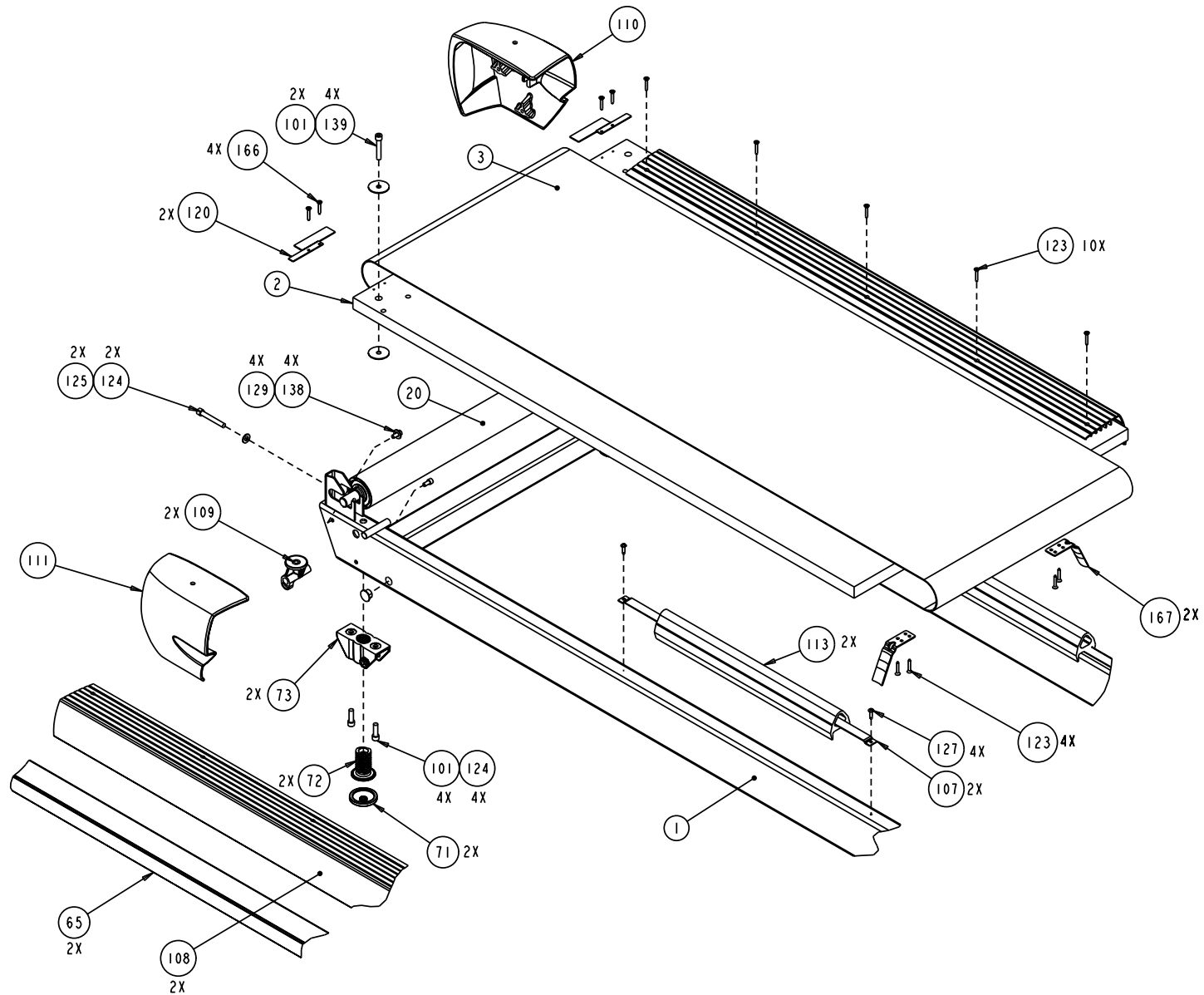

C934	P/N 45788-102	REV: K
DRAWN BY: GRANADOSIN	DATE: 05.07.04	SHEET 4 OF 8

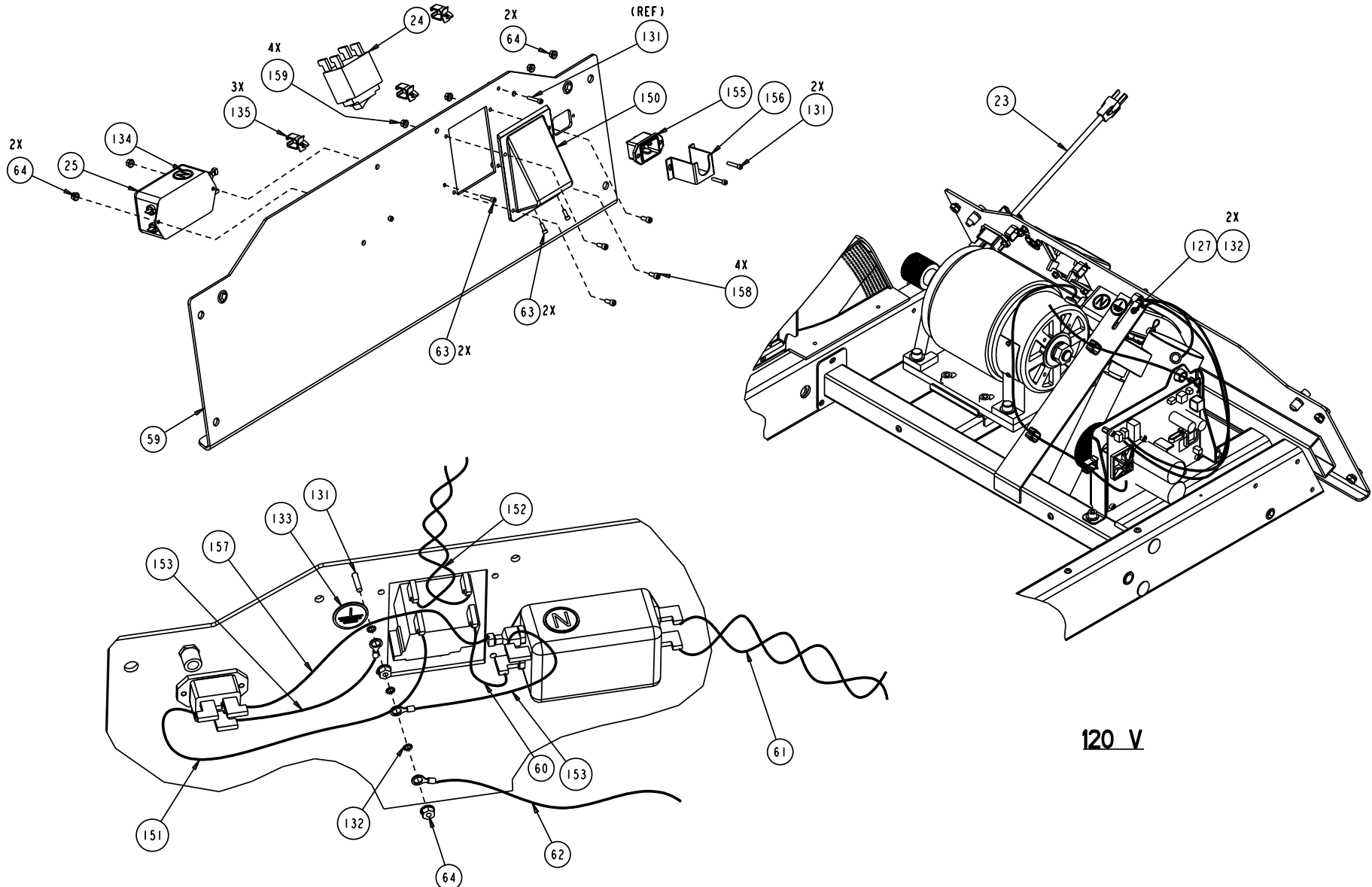

**WIRING DETAIL**  
SOME DETAIL REMOVED FOR CLARITY

C934	P/N 45788-102	REV: K
DRAWN BY: GRANADOSIN	DATE: 05.07.04	SHEET 5 OF 8

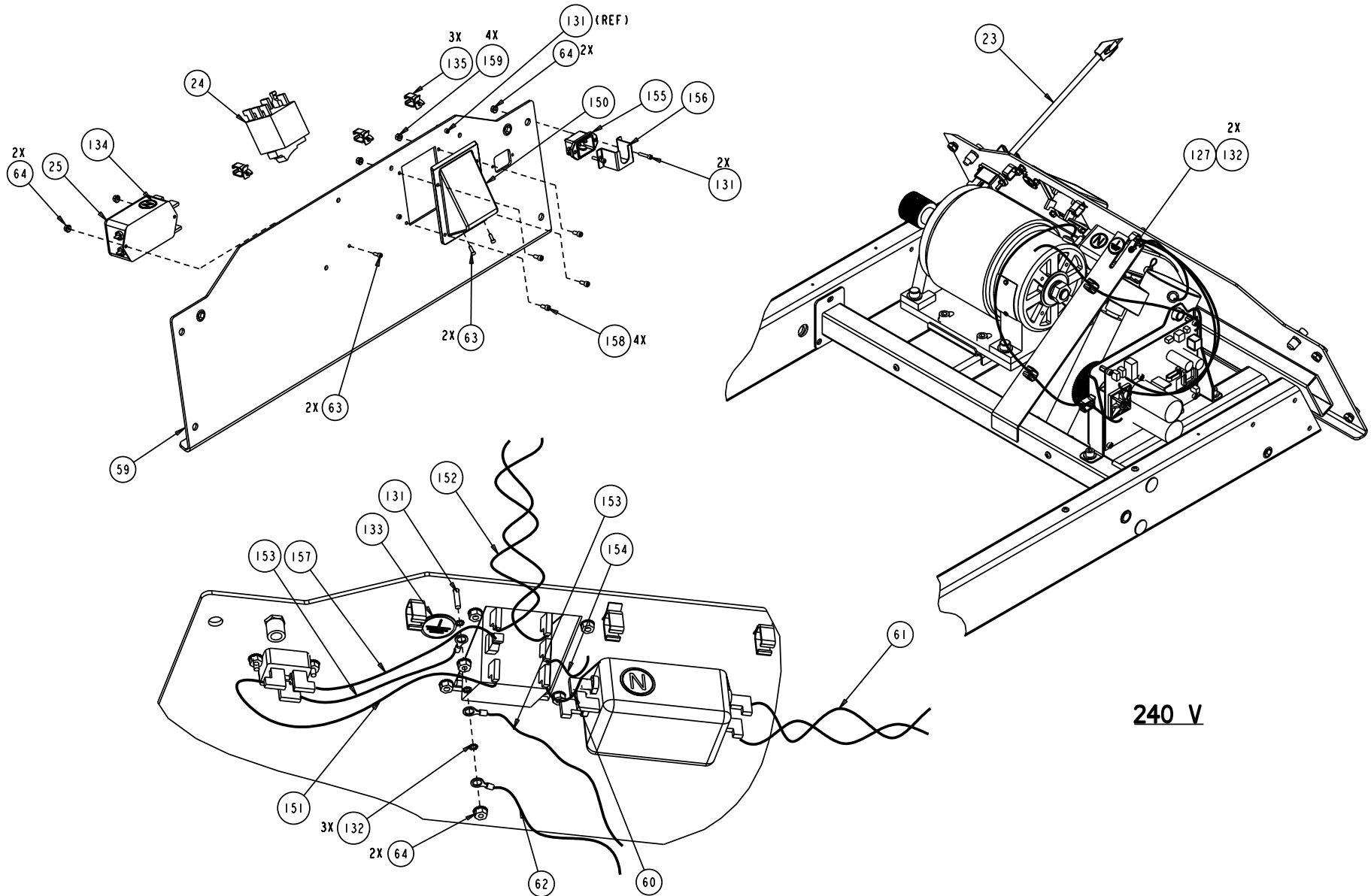

**WIRING DETAIL**  
SOME DETAIL REMOVED FOR CLARITY

C934	P/N 45788-102	REV: K
DRAWN BY: GRANADOSIN	DATE: 05.07.04	SHEET 6 OF 8

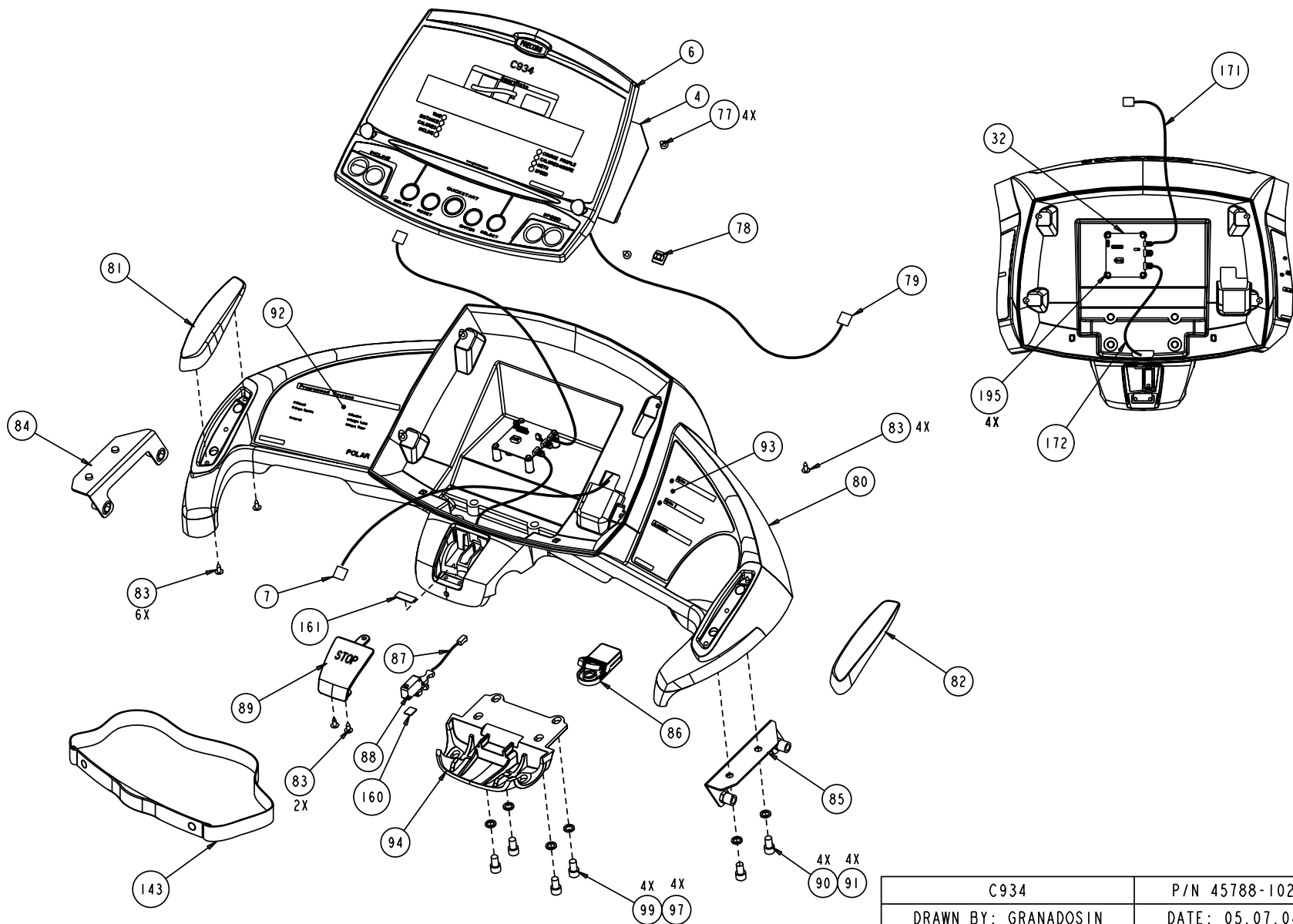

C934	P/N 45788-102	REV: K
DRAWN BY: GRANADOSIN	DATE: 05.07.04	SHEET 7 OF 8

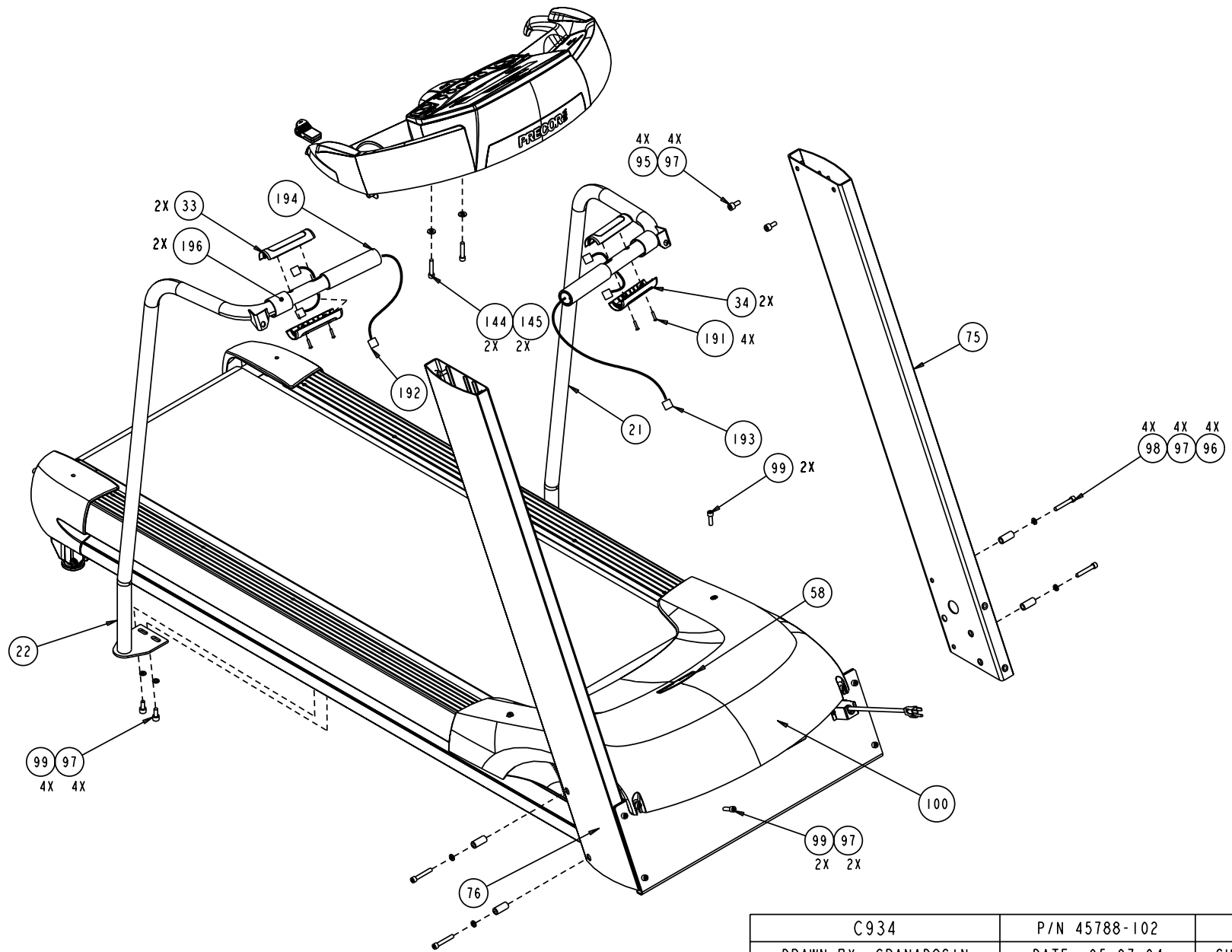

C934	P/N 45788-102	REV: K
DRAWN BY: GRANADOSIN	DATE: 05.07.04	SHEET 8 OF 8



**C934 (240 VAC)(serial code I5, KB).**

<b>Part Number</b>	<b>Description</b>	<b>Bubble Number</b>
59093-101	DECK WITH SHIPPER KIT	2
36355-122	RUNNING BELT, SIEGLING, 120 X 20 W/	3
39024-505	PCA,DISPLAY,C3	4
44968-101	ASSY,PCA&SW, C934,UPR	4.01
44969-200	PROM,C934,UPR,V2.00	5
44040-101	ASSY,DISPLAY,TOUCHSENSOR,C934,ENG,	6
44905-084	ASSY,CBL,MOD,8P8C,1-1,84"	7
59050-102	C934 LWR PCA, W/O SW, W/JUMPER	9
59050-101	LPCA, C934, WITH 120 VOLT JUMPER	9.01
59070-102	KIT, ASSY, DRIVE MOTOR,240V, CHI-HU	10
20108-101	ASSY, SPEED SENSOR, CHI-HUA MOTOR	11
44064-104	LIFT ACTUATOR, 240V	16
47101-101	ASSEMBLY, DRIVE ROLLER, STEEL	19
47102-101	ASSEMBLY, TAKE-UP ROLLER, STEEL	20
44018-107	WELDMENT, HANDRAIL, LEFT,PT, BLACK	21
44018-108	WELDMENT, HANDRAIL, RIGHT,PT, BLACK	22
45659-144	PWR CORD,250VAC,20A,NEMA 6-20RA/IEC	23
45660-144	PWR CORD,250VAC,16A,CEE 7/7RA - IEC	23.01
45429-144	PWR CORD,250VAC,13A,BS 1363 - IEC	23.02
10738-102	CKT BRKR,250V,MAGNETIC,ROCKER,	24
11224-102	FILTER,PWR LINE,250VAC,16A	25
45082-101	TOUCH SENSOR SHIELD,9 KEY	35
45904-101	LIFT PLATFORM, W/BUSHINGS, 9.3X, C9	50
HCKN050-250	SCREW,HEX,GR 5,1/2-13X2-1/2,BLK ZN	51
WBCN050-010	WASHER, FLT, 1/2, ID=.531,	52
36192-101	BUSHING, SPANNER	53
44270-101	WHEEL, LIFT	54
KACN050-019	LOCKNUT,HALF,1/2-13,ZN	55
10043-113	BEARING,FLANGE,OD=.62 ID=.5	56
KADN031-016	LOCKNUT,HALF,5/16-18,CAD PLT	57
KMCN031-023	NUT, HEX, 5/16-18, ZINC	57
44152-101	LABEL, GROUND EFFECTS	58
45667-101	9.3X, C936I FACEPLATE W/RIVNUTS	59
44528-006	ASSY,CBL,1 COND,14AWG,QK DISC,6",BR	60
45268-030	ASSY,CBL,2COND,14AWG,QK DISC FLAG,3	61
45145-016	ASSY.CBL,14AWG,RING/RING,GRN/YEL,16	62
CCNN013-038	SCREW, SKHD,6-32X3/8,SS,LK	63
KGCN013-011	LOCKNUT, STARWASHER 6-32, #6	64
44083-102	COVER, SIDERAIL	65
44063-101	FOOT PAD	71
44019-105	ASSEMBLY, REAR FOOT, M9.3X	73
44017-101	ASSEMBLY, TARGA, LEFT	75
44017-102	ASSEMBLY, TARGA, RIGHT	76
PGKN016-050	SCREW,S/T,#8X1/2,TRS,PHIL,BLK	77
12264-101	RJ-45 TELEPHONE JACK PLUG	78
44358-501	ASSY,CBL,KEYPAD,C3-12PIN TO 9 PIN	79
44065-102	DASH, CHARCOAL GRAY	80
44105-101	HAND GRIP, CONSOLE, LEFT	81
44105-102	HAND GRIP, CONSOLE, RIGHT	82

PGKN016-050	SCREW,S/T,#8X1/2,TRS,PHIL,BLK	83
44026-101	ASSY,MOUNTING BRACKET,LEFT	84
44026-102	ASSY,MOUNTING BRACKET,RIGHT	85
44021-102	CLIP ASSEMBLY	86
45283-011	ASSY,CBL,UPPER SAFETY SWITCH,11"	87
12259-102	SWITCH,MICRO,PLUNGER,SPNC	88
44086-102	STOP BUTTON	89
CAKN031-050	SCREW,SKHD,5/16-18X0.50,BLK ZN,LK	90
WBKN031-007	WASHER, FLT, 5/16, ID=.344,	91
44148-101	LABEL, DASH, LEFT, C934,EN	92
44151-101	LABEL, DASH, RIGHT, C934,EN	93
44112-102	BRACKET, HANDRAIL CLAMP	94
CCNE031-100	SCREW,SKHD,5/16-18X1.00,SS,LK	95
44060-102	SPACER, TARGA BOLT, 1.360L	96
WPNN033-005	WASHER,FLT,5/16X.562X..060,AN960C	97
CCNN031-225	SCREW,SKHD,5/16-18X2.5,BLK ZN,LK	98
CCNE031-075	SCREW,SKHD,5/16-18X.75,SS,LK	99
45451-101	ASSEMBLY, HOOD W/ WIRING DIAGRAM	100
CAKN031-175	SCREW,SKHD,5/16-18X1.75,BLK ZN,LK	101
CAKN031-200	SCREW,SKHD,5/16-18X2,BLK ZN,LK	101
44074-103	STRAP, GFX TIE DOWN	107
44082-103	TRIM, BED, CHARCOAL GRAY	108
44071-104	BRACKET, DECK MOUNT	109
46882-101	ASSY, ENDCAP, LEFT, PT	110
46882-102	ASSY, ENDCAP, RIGHT, PT	111
44089-102	ENCLOSURE, LOWER	112
44092-102	CUSHION, GFX	113
44097-102	PLATE, MOTOR	114
44102-105	VENT, HOOD, LEFT	115
44102-106	VENT, HOOD, RIGHT	116
44109-103	PIN, LIFT PIVOT, 3.38	118
44109-102	PIN, LIFT PIVOT, 2.00	119
46941-101	93X ROLLER BRIDGE, LEFT, PT	120
46941-102	93X ROLLER BRIDGE, RIGHT, PT	120.01
44117-103	COVER, LOWER ENCLOSURE	121
10217-132	BELT, DRIVE, 280J10 POLY V, TEM	122
DCKN019-100	SCREW,WOOD #10X1, L=1.00	123
WBCN031-007	WASHER,FLT,5/16X.688X.065, ZN	124
CAKN031-225	SCREW,SKHD,5/16-18X2.25,BLK ZN,LK	125
10400-103	PIN, HITCH, .093 DIA, SILVER CAD, #	126
PKCN019-075	SCREW,S/T,#10X.75,WSHXXHD,ZN	127
10178-107	BUSHING, SNAP	128
CCNN013-075	SCREW,SKHD,6-32X.75L,SS	131
WAMCN019-002	WASHER, LOCK, EXT TOOTH, #10	132
37436-101	LABEL, CHASIS NEUTRAL	134
11278-101	CABLE CLAMP,INSERT	135
10136-107	NUT RETAINER,TINNERMAN, 5/16-18	136
45784-101	GROMMET, LIFT MOTOR MOUNT, 9.3X	137
WNKN034-007	WASHER, FLT, 5/16X.500X.065,BLK ZN	138
WABCN031-006	WASHER, FEN, 5/16, ID=.331,	139
CAKN031-100	SCREW,SKHD,5/16-18X1,BLK ZN,LK	140

MGCN013-038	SCREW,MCH,6-32X3/8,PANHD,PHIL,	141
48026-101	RECEIVER, WIRELESS, HEART RATE, POL	142
CCNN031-125	SCREW, SKHD, 5/16-18 X 1.25, SS	144
WBCN031-007	WASHER,FLT,5/16X.688X.065, ZN	145
WBKN031-007	WASHER, FLT, 5/16, ID=.344,	145
44118-102	BRACKET, POWER BOX	150
44528-010	ASSY,CBL,1 COND,14AWG,QK DISC,10",B	151
44532-036	ASSY,CBL,2 COND,22AWG,MOLEX,36"	152
44534-008	ASSY,CBL,1COND,14AWG,QK DISC,8"	153
45327-006	ASSY,CBL,1 COND,14AWG,QK DISC,6",BL	154
45381-101	IEC 16/20A POWER CORD INLET	155
47027-102	POWER CORD CLAMP, SHORT.	156
45383-012	ASSY,CBL,1 COND,14AWG,QK DISC,FLAG,	157
CAKE016-038	SCREW,SKHD, #8-32 X 3/8,BLK ZN,LK	158
KGCN016-013	LOCKNUT, STARWASHER 8-32, HEX	159
42452-102	BELT TRACKER	167
HCCN031-125	SCREW,HEX,GR 5,5/16-18X1.25,ZN	168
44135-103	HARDWARE KIT, 9.3X	200
20002-112	BRUSH, MOTOR (PAC SCI YP00521)	202
10186-111	WRENCH, ALLEN, 1/4, 3 X 10	204
11075-020	FUSE,200MA,250VAC,SLOW,RADIAL	205
11075-102	FUSE,1.00A,250VAC,SLOW,RADIAL	206
11075-105	FUSE,2.00A,250VAC,SLOW,RADIAL	207
44165-105	LABEL, WIRING DIAGRAM	209
59054-101	9.3X, C93X ENDCAP REPLACEMENTKIT	210
59060-101	9.3X BELT TRACKER KIT	215
20002-113	BRUSH W/ LEAD, CHI HUA 93 SERIES DC	235
20002-117	GROUND BRUSH, CHI HUA 93 SERIES DC	236
44132-105	LITERATURE KIT,C934	999